

Commissioning

- Secure the mains feed cable back under the cable clamp (6) and secure the lamp holder plate (4) with the 2 x screws removed in 3 above – being careful not to trap or damage internal cables.
- **Diagram C.** Place the bracket over the pre-drilled holes in the mounting surface, and secure using the screws / wall plugs provided.
- Fit bulb as detailed below.
- Replace the glass cover (1)..
- Replace fuse or circuit breaker and switch on. Your light is now ready for use.

Diagram C. Shade shape may vary from that shown.

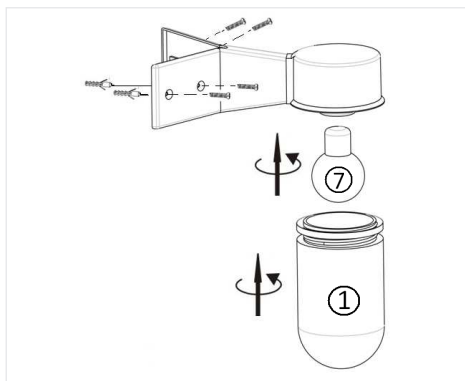

Fitting/replacing bulbs

- When changing a bulb, always switch off at the mains and allow the bulb to cool before handling.
- Always use the correct type and wattage bulb. Using the incorrect wattage bulb will damage the bulb and ballast.
- Used bulbs should not be disposed of with household waste. Please recycle where facilities exist.
- Unscrew the bulb anticlockwise to remove.
- Insert the bulb gently into the fitting. Screw clockwise into the lampholder.



We recommend cleaning with a soft dry cloth. Do not use solvents or abrasive cleaners as these could damage the finish.

Shade – Remove and wash in warm water or just use a damp cloth. Do not use abrasive materials as these will damage the finish.

Recycling advice



Waste electrical products should not be disposed of with household waste. Please recycle where facilities exist. Check with your Local Authority or retailer for recycling advice.

Safety information

For your safety, always switch off the supply before changing lightbulbs, or cleaning.

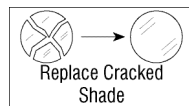

This light source is protected by a shade. This part must be replaced immediately should the shade become cracked or damaged. This fitting must not be used without the shade in place.

Iss.2 28072015

Instruction leaflet

Ware Outdoor Wall

EL-40088



saxby
lighting

Thank you for purchasing this light fitting. Please read the instructions carefully before use to ensure safe and satisfactory operation of this product. Please retain these instructions for future reference.

Warning



This light fitting is Double Insulated and does not require connection to an Earth circuit.

Please read these instructions carefully before commencing any work.

This unit must be fitted by a competent and qualified electrician.

Install in accordance with IEE Wiring regulations and current Building Regulations.

To prevent electrocution switch off at mains supply before installing or maintaining this fitting. Ensure other persons cannot restore the electrical supply without your knowledge.

This light fitting should be connected to a fused circuit.

If replacing an existing fitting, make a careful note of the connections.

Always use the correct type and wattage bulb. Exceeding the bulb wattage will damage the product. When changing a bulb, always switch off at the mains and allow the old bulb to cool down before handling.

Dispose of used bulbs carefully and responsibly.

This product is suitable for dimming when used in conjunction with a dimmable lamp. Please ensure verification of dimming abilities with the lamp manufacture prior to use.

Waste electrical products should not be disposed of with household waste. Please recycle where facilities exist. Check with your local authority or retailer for recycling advice.

Installation

Existing fittings must be completely removed before installation of a new product. Before removing the existing fitting, **carefully note the position of each set of wires.**

- Determine the position of your light fitting taking into account the exit position of the cable. Ensure that the mounting surface is solid, preferably a brick or block wall and ensure that there are no other cables or pipes beneath the surface. Use appropriate fixings.
- **Diagram A.** Unscrew the glass cover (1) from the body of the fitting (2). Use the corner bracket as a template and mark and drill the (four) mounting holes (3) – but do

Diagram A. Shade shape may vary from that shown.

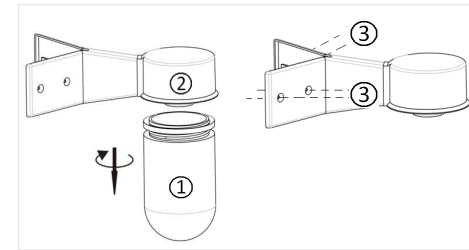

not fix to the surface yet.

- **Diagram B.** Remove the 2 x screws in the lamp holder housing plate (4) and remove it from the fitting. This will enable you to access the internal terminal block (5). Release the 2 x screws in the cable clamp (6).
- Wire as detailed below.

Diagram B. Shade shape may vary from that shown.

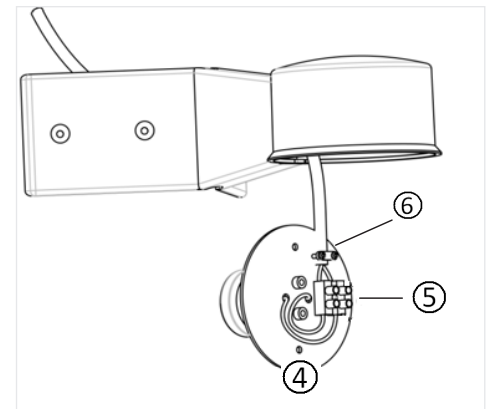

Specification

Voltage: 240V 50Hz a.c.
Lamp: 40W E27 GLS
IP rating: 44

Layout

- Plan the desired layout of this fitting carefully, ensuring the cables will reach the distance between the junction box and the light fitting.
- Avoid locating any cables in positions that would cause a hazard. Position cables and outdoor rated junction boxes (not supplied) away from areas where they may be at risk from being cut, trapped or damaged.
- We recommend that you use H05RN-F specification cable which is an outdoor grade, rubber sheathed cable. The mains supply cable must have a minimum cross sectional area of 1.0mm²
- Cables must be protected using suitable conduit or plastic trunking.

Wiring

Having correctly identified the wiring from your light fitting, connect to the approved outdoor rated external terminal block in the following way:

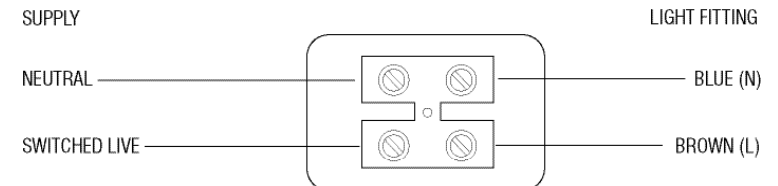

Check that...

- You have correctly identified the wires
- The connections are tight
- No loose strands have been left out of the connection block.