

Thank you for purchasing this light fitting.
Please read the instructions carefully before use to ensure safe and satisfactory operation of this product.
Please retain these instructions for future reference.

Warning

This is a Class I product and must be earthed.

Please read these instructions carefully before commencing any work.

This unit must be fitted by a competent and qualified electrician.

Install in accordance with IEE Wiring regulations and current Building Regulations.

To prevent electrocution switch off at mains supply before installing or maintaining this fitting. Ensure other persons cannot restore the electrical supply without your knowledge. If you are in any doubt, please consult a qualified electrician.

This light fitting should be connected to a circuit with a 30mA RCD fitted.

If replacing an existing fitting, make a careful note of the connections.

This system contains non-replaceable parts and cannot be serviced. If damage occurs the part should be scrapped.

Waste electrical products should not be disposed of with household waste. Please recycle where facilities exist.

Check with your local authority or retailer for recycling advice.

This product is not suitable for dimming.

This product is rated at IP44.

This product is not suitable for location in or near a marine or sea environment.

The entire unit gets hot whilst on for a period of time.

Specification

Voltage:	240V 50Hz a.c.
Lamp:	3.3W 30 LED's
IP rating:	44

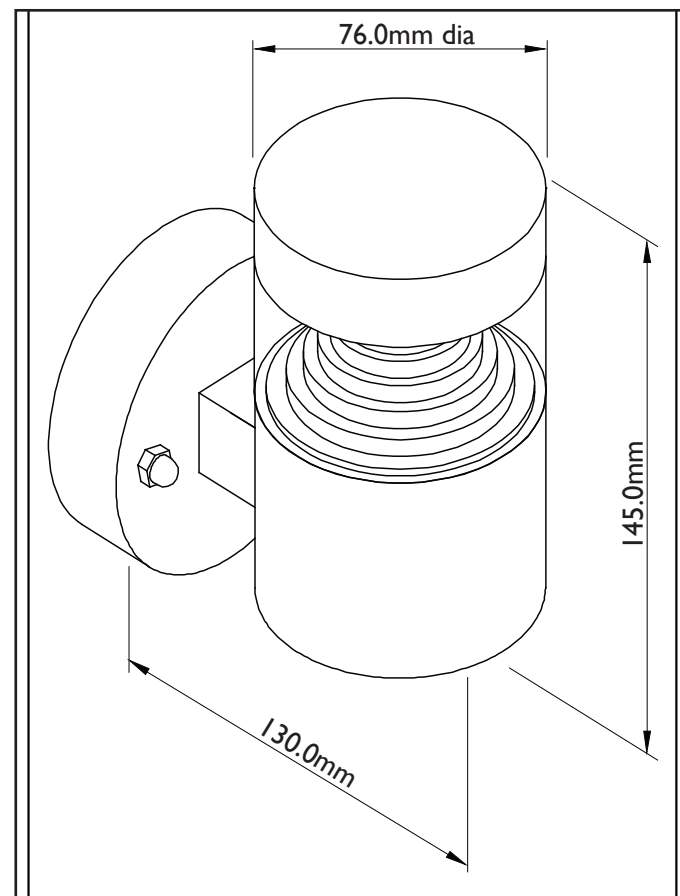

Layout

- Plan the desired layout of this fitting carefully, ensuring the cables will reach the distance between the junction box and the light fitting.
- Avoid locating any cables in positions that would cause a hazard. Position cables and outdoor rated junction boxes (not supplied) away from areas where they may be at risk from being cut, trapped or damaged.
- We recommend that you use H05RN-F specification cable (not supplied) which is an outdoor grade, rubber sheathed cable. The mains supply cable must have a minimum cross sectional area of 1.0mm²
- Cables must be protected using suitable conduit or plastic trunking.

Installation

Existing fittings must be completely removed before installation of a new product. Before removing the existing fitting, **carefully note the position of each set of wires**.

- Remove mounting box (A) from the product by removing dome nuts (C) and washers (D). Pull terminal block off of retaining pegs. Carefully pierce a small hole in the rubber gasket in the centre of the mounting box to allow the cable to pass through.
- Thread the cable through the hole, ensuring the drain hole is at the base of the mounting box.
- Fix the mounting box to the wall using the screws and plugs supplied (B). Ensure the wall is capable of holding the weight of the product. Take care to avoid damaging any concealed wiring and pipes. The correct fixings should be used for brick or cavity walls.
- Wire as detailed below.

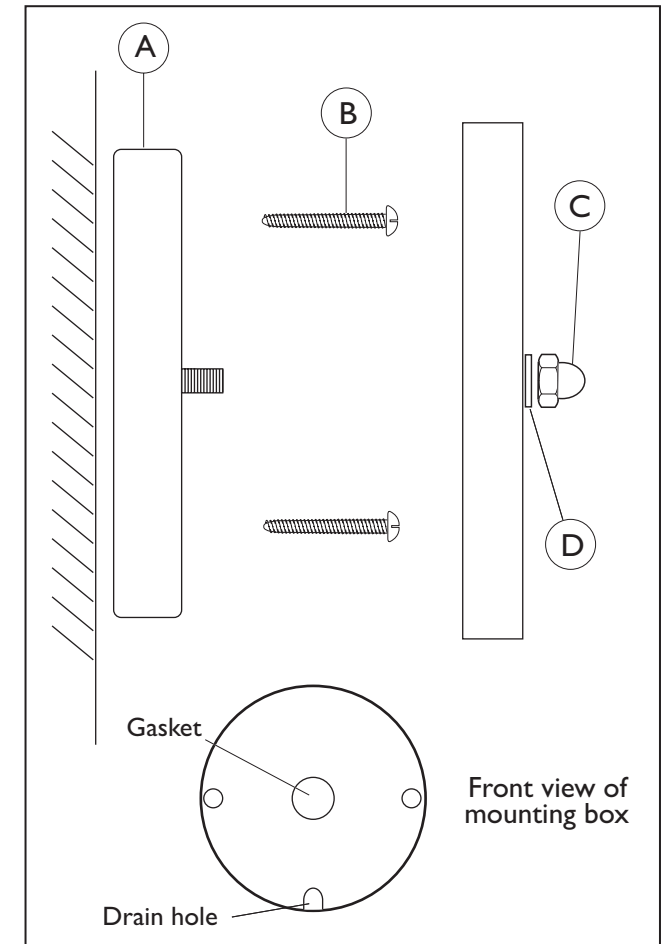

Wiring

Having correctly identified the wiring from your existing light fitting, pull the wire through the hole and connect to the connection block inside the product in the following way:

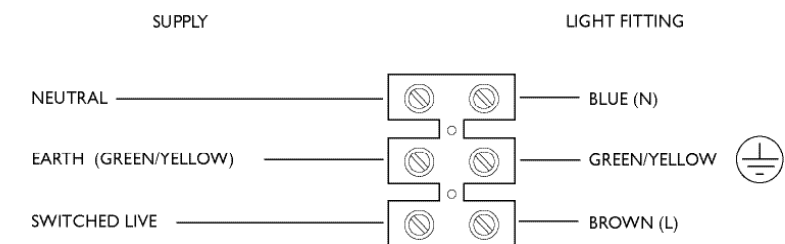

Check That

- You have correctly identified the wires.
- The connections are tight.
- No loose strands have been left out of the connection block.

Commissioning

- Fit the product back on to the mounting box and refit washers (D) and dome nuts (C), tighten dome nuts to secure.
- Replace fuse or circuit breaker and switch on. Your light is now ready for use.

Fitting / Replacing Bulbs

This system contains non-replaceable parts and cannot be serviced. If damage occurs the part should be scrapped.

Care and Cleaning

Do not use solvents or abrasive cleaners as these could damage the finish.

In normal circumstances, stainless steel is very resistant to corrosion. It does however require maintenance to preserve the high quality appearance. Wash the product with warm soapy water, removing all surface deposits. Rinse with clear water and with a soft cloth, wipe dry.

In some cases, surface corrosion may arise after installation. This is normally caused by tiny iron particles left behind after the brushing process when finishing.

Wash and dry as detailed above. Then with a soft cloth soaked with a protective oil, wipe all over.

However if the product is subject to extreme environmental conditions such as marine locations, industrial pollution and acid rain these maintenance procedures should be carried out around four times a year. For severe corrosion, non-abrasive cream cleaners or proprietary stainless steel cleaners should be used to remove the corrosion. Wash and dry as detailed above. Then with a soft cloth soaked with a protective oil, wipe all over.

Do not clean the units with a pressure washer.

Recycling Advice



Waste electrical products should not be disposed of with household waste. Please recycle where facilities exist. Check with your Local Authority or retailer for recycling advice.

Safety Information

For your safety, always switch off the supply before changing lightbulbs, or cleaning.

This system contains non-replaceable parts and cannot be serviced. If damage occurs the part should be scrapped.



Saxby Lighting. BH23 3PE

saxby
lighting



Pyramid LED Wall Light

13928