

INSTALLATION MANUAL

68016

ecolight



DARK
LIGHT

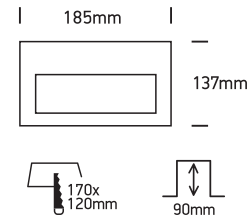

230V | 2W | IP54 | Die cast

Complete with driver.
Supplied with box for concrete installation and
kit for gypsum installation.

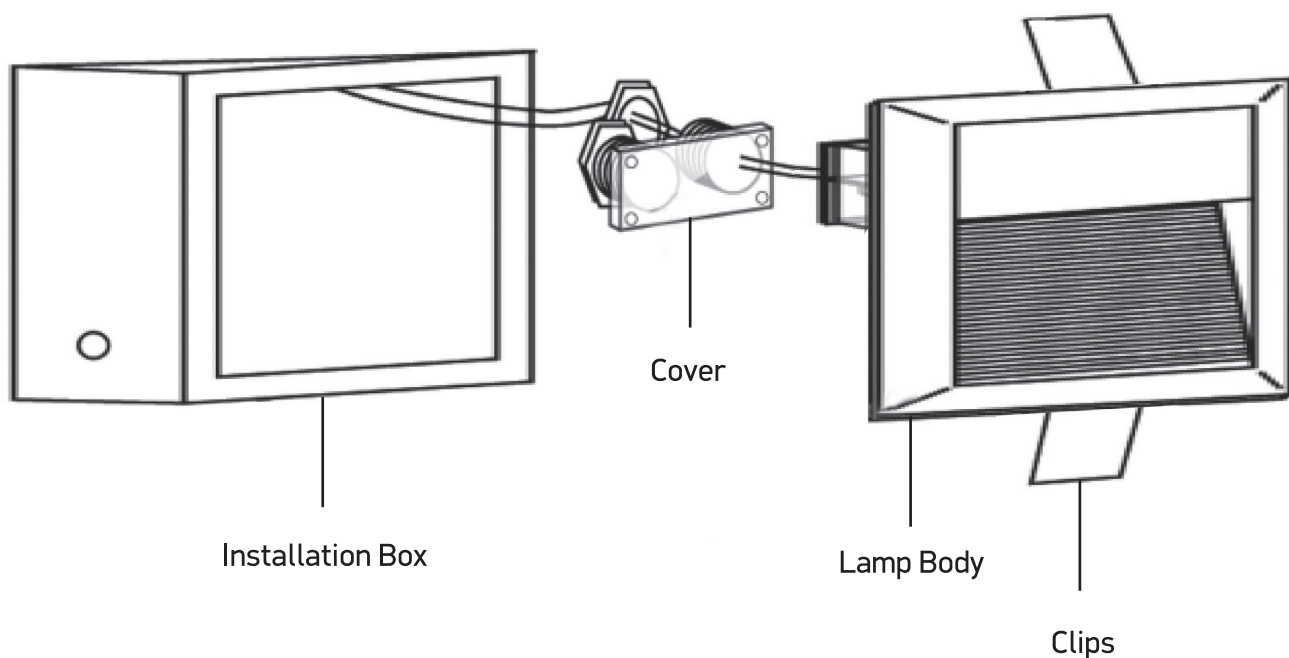

Warnings:

1. Make sure that the product is installed properly before connecting to electricity.
2. Do not cover the fitting.
3. Maintenance and installation should only be carried out by a professional electrician.